



SGL50

Elevator traction machine

Voltage : 380V
 Suspension : 2 : 1
 PZD140B Brake : DC110V 2×0.89A
 PZD140 Brake : DC110V 4×0.69A
 Weight : 1120kg
 Max.Static Load : 14000kg

Spec	Load (kg)	Lift Speed (m/s)	Sheave Diam(mm)	Rope Sheave (mm)	Double Roping	Current (A)	Torque (Nm)	Rated Speed (rpm)	Frequency (Hz)	Power (kW)	Pole	Rating	INS.Class	IP Code
SGL50-103P0	1000	3.0	Φ560	10xΦ13x18	YES	42.8	955	205	34.2	20.5	20	S5-50%	F	IP21
SGL50-104P0	1000	4.0	Φ560	10xΦ13x18	YES	56.5	955	273	45.5	27.3	20	S5-50%	F	IP21
SGL50-123P0	1250	3.0	Φ560	10xΦ13x18	YES	53.3	1190	205	34.2	25.5	20	S5-50%	F	IP21
SGL50-124P0	1250	4.0	Φ560	10xΦ13x18	YES	72	1190	273	45.5	34	20	S5-50%	F	IP21
SGL50-133P0	1350	3.0	Φ560	10xΦ13x18	YES	57.2	1290	205	34.2	27.7	20	S5-50%	F	IP21
SGL50-134P0	1350	4.0	Φ560	10xΦ13x18	YES	75.5	1290	273	45.5	36.9	20	S5-50%	F	IP21
SGL50-162P5	1600	2.5	Φ560	12xΦ13x18	YES	56.5	1525	171	28.5	27.3	20	S5-50%	F	IP21
SGL50-163P0	1600	3.0	Φ560	12xΦ13x18	YES	69.5	1525	205	34.2	32.7	20	S5-50%	F	IP21
SGL50-164P0	1600	4.0	Φ560	12xΦ13x18	YES	93	1525	273	45.5	43.6	20	S5-50%	F	IP21
SGL50-202P5	2000	2.5	Φ560	12xΦ13x18	YES	72	1910	171	28.5	34.2	20	S5-50%	F	IP21
SGL50-203P0	2000	3.0	Φ560	12xΦ13x18	YES	90	1910	205	34.2	41	20	S5-50%	F	IP21
SGL50-204P0	2000	4.0	Φ560	12xΦ13x18	YES	120	1910	273	45.5	54.3	20	S5-50%	F	IP21

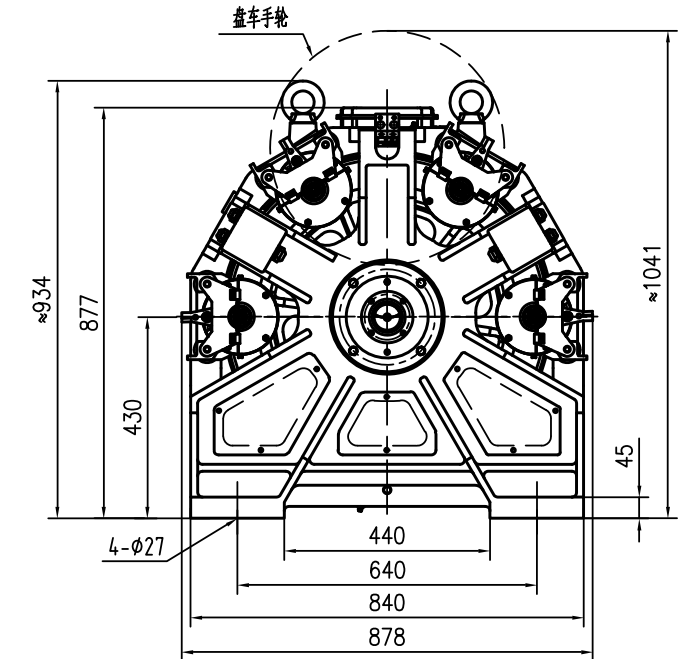
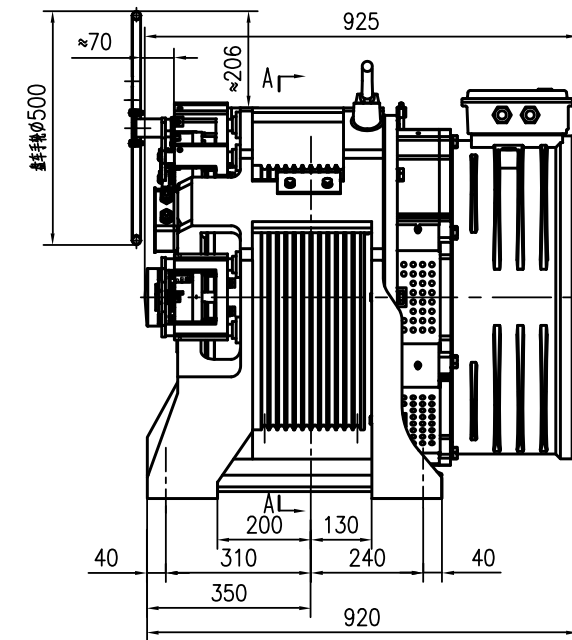

REMARK

- 1.This machine can be configured with the manual wheel.
- 2.Brakes PZD140B for 1000-1350kg;PZD140 for 1600-2000kg.

